



RECTANGULAR VACUUM CUPS WITH BALL VALVE AND HIGH SELF-LOCKING SUPPORT

These cups also represent a true mobile clamping system. They differ from the above cups for their exceptional height. They are composed of:

- A sturdy, tall aluminium support with a wide surface at the base limited by a seal whose purpose is to fix it to the bearing surface.
- A standard rectangular flat cup which is cold fitted onto the upper part of the support for gripping the load.
- A ball valve that opens up creating vacuum, only when activated by the load to be gripped.
- Two quick couplings for vacuum connection.

The gripping plane of these cups is covered with a special non-slip plastic coating, which is particularly suited for clamping glass and smooth marble.

The detection of vacuum for gripping and releasing the support from the bearing surface and gripping and releasing the load can be made via three-way vacuum valves or solenoid valves.

All cups with self-locking support of this and other ranges with the gripping plane at the same height can be used simultaneously, even if they are of different types or have different sizes.

Note: Available with support for mechanical fixing with code 28, instead of 18.

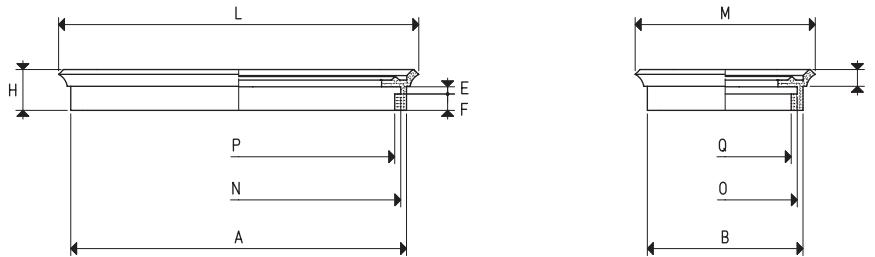

SPARE VACUUM CUPS

Item	Force Kg	Volume cm ³	A	B	E	F	G	H	L	M	N	O	P	Q	Weight g
01 120 90 *	24.0	42.9	107	78	3	7.5	7.5	17.5	117	87	102	73	97	68	38.8
01 150 75 *	25.0	43.5	137	62	3	7.5	7.5	16.5	147	72	132	57	127	52	41.2
01 300 80 *	60.0	117.6	288	68	3	7.5	7.5	17.5	297	77	284	64	278	58	80.0
01 300 150 *	113.0	268.5	288	138	3	7.5	7.5	17.5	297	147	284	134	278	128	90.0

* Complete the code indicating the compound: A= oil-resistant rubber; N= natural para rubber; S= silicone; BA= stain-resistant Biond

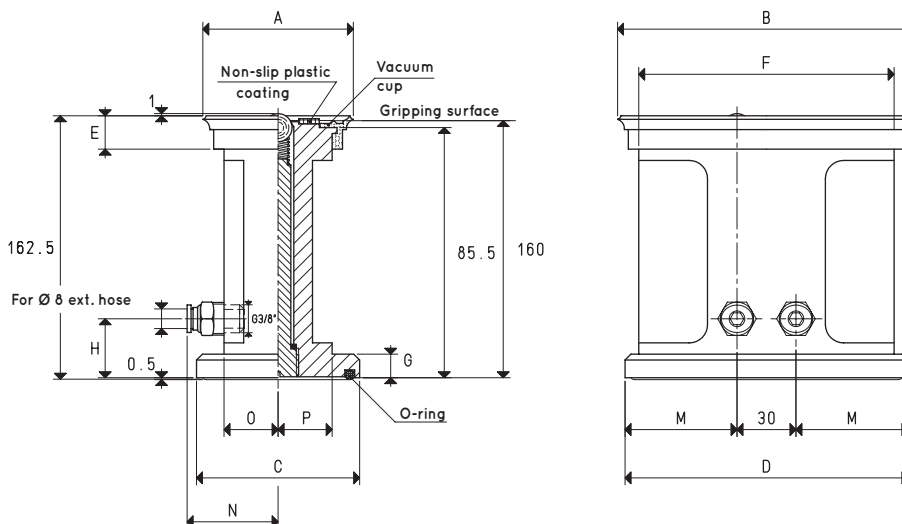

ROUND VACUUM CUPS WITH BALL VALVE AND HIGH SELF-LOCKING SUPPORT

Item	Force Kg	A	B	C	D	E	F	G	H	M	N	O	P	Vacuum cup item	O-ring item	Weight Kg
18 120 90/160 MT *	24.0	90	120	98	128	17.5	102	12	30	49	51.0	35.0	35.0	01 120 90	00 16 10	3.450
18 150 75/160 MT *	25.0	75	150	83	144	16.5	130	12	30	57	43.5	27.5	27.5	01 150 75	00 16 10	3.262
18 300 80/160 MT *	60.0	80	300	90	310	17.5	284	15	33	140	47.0	31.0	31.0	01 300 80	00 18 10	7.906
18 300 150/160 MT *	113.0	150	300	160	310	17.5	284	15	33	140	83.0	67.0	67.0	01 300 150	00 18 11	13.110

* Complete the code indicating the compound: A= oil-resistant rubber; N= natural para rubber; S= silicone; BA= stain-resistant Biond

Note: The force of the vacuum cups indicated in the table represents 1/3 of the value of the theoretical force calculated at a level of vacuum of -75 KPa and a factor of safety 3.

Transformation ratio: N (newton) = Kg x 9.81 (force of gravity) inch = $\frac{\text{mm}}{25.4}$; pounds = $\frac{\text{g}}{453.6} = \frac{\text{Kg}}{0.4536}$