

# MULTI-STAGE VACUUM GENERATORS PVP 25 ÷ 75 MDX / MDXLP



3D drawings are available on vuototecnica.net

This line of generators is available with suction rates between 20 and 103 m<sup>3</sup>/h. The supply pressure goes from 4-6 bar for MDX items and from 1-3 bar for MDXLP items. The maximum level of vacuum is -90 KPa. Characterised by their new generation of ejectors, boasting an excellent ratio between the quantity of air consumed and that suctioned, benefiting operational consumption. They are fully made with anodised aluminium, with stainless steel ejectors and screws. The tightness seal is made from EPDM, while the reed valves are made as standard and in VITON<sup>®</sup>, upon request. The "free-flow" SSX high sound damping silencers installed as standard on the air exhaust.

They are equipped with additional threaded connections for increased points of usage or for the installation of measurement or control tools. Upon request, can be supplied with a compressed air energy savings kit ES (ENERGY SAVING SYSTEM), composed of a pneumatic vacuum regulator, a pneumatic coaxial shutter supply valve, a check valve and necessary tubing.

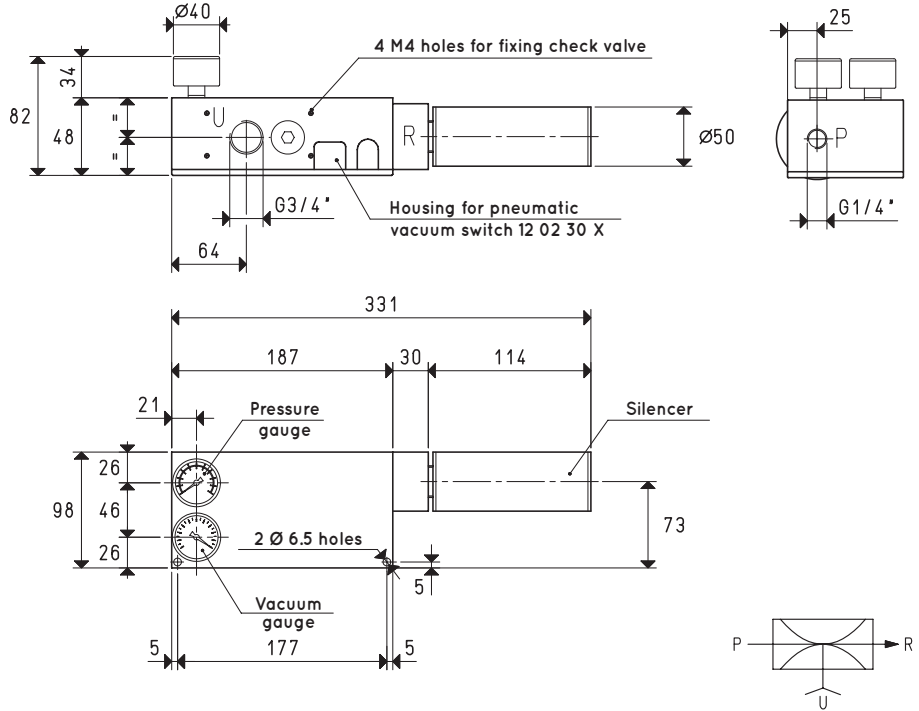

P=COMPRESSED AIR CONNECTION      R=EXHAUST      U=VACUUM CONNECTION

Item		PVP 25 MDX			PVP 35 MDX			PVP 50 MDX				
Intake air flow rate	m <sup>3</sup> /h	35	39	43	47	52	57	57	62	68		
Maximum level of vacuum	-KPa	65	82	90	65	82	90	65	82	90		
Final pressure	abs. mbar	350	180	100	350	180	100	350	180	100		
Supply pressure	bar	4	5	6	4	5	6	4	5	6		
Optimal supply pressure	bar			6			6			6		
Air consumption	Nl/s	2.3	2.8	3.2	3.4	4.1	4.8	4.7	5.6	6.5		
Temperature of use	°C		-20 / +80				-20 / +80				-20 / +80	
Noise level at optimal supply pressure	dB(A)		58				58				60	
Weight	Kg		1.71				1.73				1.75	

Item		PVP 25 MDXLP			PVP 35 MDXLP			PVP 50 MDXLP				
Intake air flow rate	m <sup>3</sup> /h	20	28	35	26	38	47	31	48	58		
Maximum level of vacuum	-KPa	30	64	88	30	64	88	30	64	88		
Final pressure	abs. mbar	700	360	120	700	360	120	700	360	120		
Supply pressure	bar	1	2	3	1	2	3	1	2	3		
Optimal supply pressure	bar			3			3			3		
Air consumption	Nl/s	2.2	3.3	4.4	3.4	5.0	6.5	4.5	6.6	8.6		
Temperature of use	°C		-20 / +100				-20 / +100				-20 / +100	
Noise level at optimal supply pressure	dB(A)		62				68				74	
Weight	Kg		1.71				1.73				1.75	

Spare parts		PVP 25 MDX / MDXLP	PVP 35 MDX / MDXLP	PVP 50 MDX / MDXLP
Sealing kit and reed valves	item	00 KIT PVP 25 MDX	00 KIT PVP 35 MDX	00 KIT PVP 50 MDX
Vacuum gauge	item	09 03 15	09 03 15	09 03 15
Pressure gauge	item	09 03 25	09 03 25	09 03 25
Silencer	item	SSX 3/4"	SSX 3/4"	SSX 3/4"

Note: All vacuum values indicated in the table are valid at the normal atmospheric pressure of 1013 mbar and obtained with a constant supply pressure.

Vacuum generator supply must be carried out with non-lubricated compressed air, 5 micron filtration, in accordance with standard ISO 8573-1 class 4.

Transformation ratio: N (newton) = Kg x 9.81 (force of gravity)

inch =  $\frac{mm}{25.4}$  ; pounds =  $\frac{g}{453.6} = \frac{Kg}{0.4536}$

Adapters for GAS - NPT threading available on page 1.130



# MULTI-STAGE VACUUM GENERATORS PVP 25, PVP 35 and PVP 50 MDX / MDXLP

Air flow rate (NI/s) at different levels of vacuums (-KPa) at optimal supply pressure

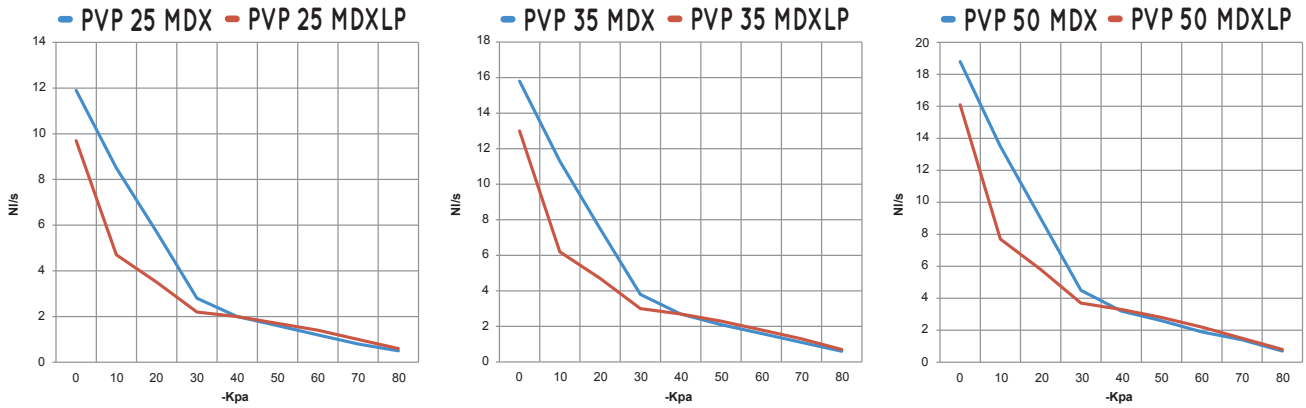

Generator item	Supp. press. bar	Air consumption NI/s	Air flow rate (NI/s) at different levels of vacuum (-KPa) at optimal supply pressure										Max vacuum -KPa
			0	10	20	30	40	50	60	70	80		
PVP 25 MDX	6.0	3.2	11.9	8.5	5.7	2.8	2.0	1.6	1.2	0.8	0.5	90	
PVP 35 MDX	6.0	4.8	15.8	11.3	7.5	3.8	2.7	2.1	1.6	1.1	0.6	90	
PVP 50 MDX	6.0	6.5	18.8	13.5	9.0	4.5	3.2	2.6	1.9	1.4	0.7	90	
PVP 25 MDXLP	3.0	4.4	9.7	4.7	3.5	2.2	2.0	1.7	1.4	1.0	0.6	88	
PVP 35 MDXLP	3.0	6.5	13.0	6.2	4.7	3.0	2.7	2.3	1.8	1.3	0.7	88	
PVP 50 MDXLP	3.0	8.6	16.1	7.7	5.8	3.7	3.3	2.8	2.2	1.5	0.8	88	

Evacuation rates (ms/l = s/m<sup>3</sup>) at different levels of vacuums (-KPa) at optimal supply pressure

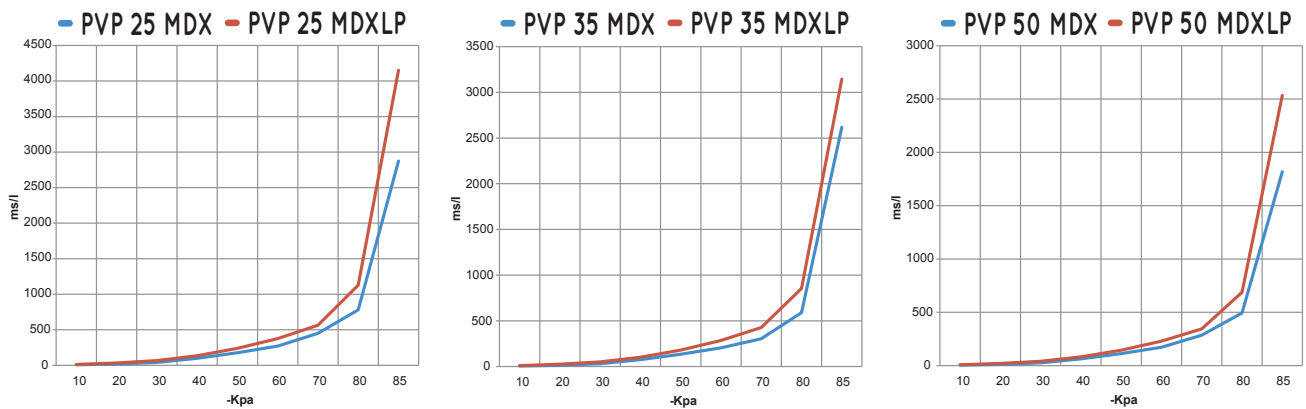

Generator item	Supp. press. bar	Air consumption NI/s	Evacuation rates (ms/l = s/m <sup>3</sup> ) at different levels of vacuums (-KPa) at optimal supply pressure										Max vacuum -KPa
			10	20	30	40	50	60	70	80	85		
PVP 25 MDX	6.0	3.2	7.5	18.8	41.3	99.3	177.7	271.9	451.4	781.0	2874	90	
PVP 35 MDX	6.0	4.8	5.6	14.1	31.2	74.9	134.0	205.1	340.5	589.1	2618	90	
PVP 50 MDX	6.0	6.5	4.7	11.9	26.2	62.8	112.4	172.0	285.5	494.0	1818	90	
PVP 25 MDXLP	3.0	4.4	13.0	33.3	67.2	134.4	238.0	376.0	564.0	1128.0	4151	88	
PVP 35 MDXLP	3.0	6.5	9.8	25.2	50.9	101.9	180.3	284.9	427.3	854.7	3145	88	
PVP 50 MDXLP	3.0	8.6	7.9	20.3	41.0	82.0	145.3	229.5	344.3	688.5	2534	88	